

DDS 54

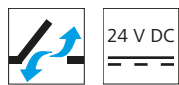

Performance features

- » For opening single-leaf doors up to 90°
- » With motor electronics controlled via microprocessor
- » High force of pressure due to special chain stabilisation
- » Control output for on-site electronic door release
- » Guarantees the necessary supply air and open escape routes
- » The door remains operable by hand
- » Automatic motor lock, Ikon or Ehem, can be combined
- » Programmable drive functions and different drive parameters
- » Additional passive and active anti-trap protection system for the main closing edges
- » Bracket set included

Approvals / Certificates

Article also available with the following permissions under other article numbers. Technical data may deviate. Find out about permission details from your D+H Partner.



CNBOP-PIB

Potential drive options

You can find the explanations for the icons on the last page.

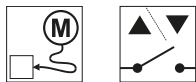

Dimensions

All specifications in mm

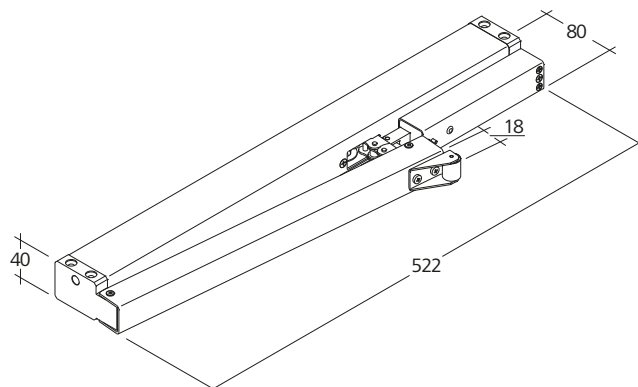

Technical data

	DDS 54
Supply	24 V DC / $\pm 15\%$ / 1 A
Duty cycle	30 % (ON: 3 min. / OFF: 7 min.)
Force of pressure	500 N
Tensile force	500 N
Service life	20000 double strokes
OPEN running speed	11.8 mm/s
CLOSED running speed	11.8 mm/s
Type of protection	IP 32
Emission sound pressure level	LpA \leq 70 dB(A)
Temperature range	-5 °C ... +75 °C *
Fire resistance	B300 (30 min / 300 °C)
Housing	Aluminium
Surface	Powder-coated
Colour	White aluminium (~ RAL 9006)
Connection	2.5 m silicone cable
W x H x D	522 x 40 x 80 mm
Weight	2.00 kg

* In accordance with VdS 2580

Design

Type	Art. No.	Stroke	Remark
DDS 54/500	23.002.40	500 mm	
DDS-PLP	26.500.00	500 mm	Variable equipment possible



HS "High speed"

In the case of SHEV, the high-speed function is used for reliably reaching the defined end position in 60 s. In daily ventilation mode, the drive runs quietly and quickly, as usual.



Function programming

Option for customised configuring of drive parameters (e.g. stroke) via software and associated service tools for drives equipped with PLP, BSY or BSY+ electronics.



BRV signal

Acknowledgement from the drive, via a control cable, to confirm that it has been completely extended or retracted. When used with the AT 41 and ERM 44 modules, this signal is sent to the central building control system, the modules themselves, or to the locking drive. The BRV signal is not isolated.



ACB (Advanced Communication Bus)

Enables direct bus communication between the controller and the drive for, for example, control with perfect positioning or drive feedback. Communication is via the open source Modbus protocol, and it enables the drive to be combined with an ACB-capable control panel or enables it to be directly connected to higher-level controllers such as a building management system.



BSY+ (synchronisation of drives)

BSY+ enables communication and synchronisation between different components in the window. For example between the chain drives, during synchronous operation, or between window and locking drives (e.g. FRA 11 BSY+ or VLD-BSY+).



SGI signal (position reporting)

In combination with the D+H servo plug-in unit SE 622 or the BSY-gateway BSY-GW-024-010-U, the drives can be controlled with perfect positioning.



SKS (closing edge protection)

Drive option, which enables an anti-trap strip or presence detector to be connected directly to the drive (terminal resistor 5.6 kΩ).



Audible signal (corresponding to protection class)

AS2 corresponding to "Protection class 2" in accordance with ZVEI risk assessment through an audible warning signal in the "CLOSED" running direction. AS3 corresponding to "Protection class 3" in accordance with ZVEI risk assessment, in addition to AS2, stops the drive for 11 s with a remaining stroke of 28 mm.



End position message (OPEN / CLOSED)

Drive feedback via an integrated isolated switching contact. This happens if the chain / rack and pinion has moved completely out or in.



SBD side bow chain

Drive chain with rigid backing, bends in the direction of the hinge. Drive is fixed in place (not rotatable).



SBU side bow chain

Drive chain with rigid backing, bends in the direction of the hinge. Drive is fixed in place (not rotatable).



WS (use in swimming pool)

Available as an option for rack and pinion drives to make them suitable for use in swimming pools. The drive is equipped with an A4 rack and pinion, A4 eyebolt and a gearbox with hardened stainless steel pinion.



W (use outdoors)

Available as an option for rack and pinion drives to make them suitable for outdoor use. The drive is equipped with a pressure release vent (depending on installation), condensation protective coating on the electronics and a gearbox with hardened stainless steel pinion.